

Doc #
MA-A040400-D001

FITTING INSTRUCTIONS

Honda CRF1000L Africa Twin Luggage Rack

Revision: 0
 Date: 2017-06-08
ENGLISH

A qualified, experienced motorcycle or vehicle technician should install Motorradical 3DX products. If you are unsure of your ability to properly install a product, please have the product installed by your local motorcycle dealer. Motorradical takes no responsibility for damages caused by improper installation. All screws, bolts and nuts, including all replacement hardware provided by Motorradical, should be tightened to the torque specified in the OEM maintenance manual for your motorcycle. If no torque specifications are provided in the OEM maintenance manual, a Torque Chart is available on our website. All screws, bolts and nuts should be checked after driving the first 50 km to ensure that all are tightened to the proper torque. Medium strength liquid thread-locker (i.e., "Locktite") should be used to secure all screws bolts and nuts.

Packaging Weight: 900g
Packaging Dimensions: 300mm (W) x 390 (L) x 80 (H)

KIT CONTENTS:

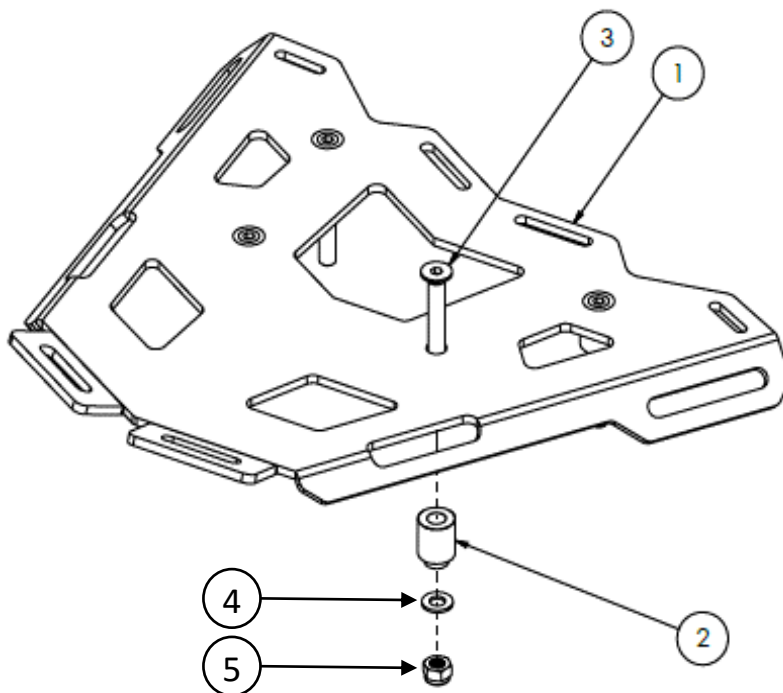

Parts List

No.	Description	Part Number	QTY
1	Africa Twin Luggage Rack Plate	SA-A04040001	1
2	Spacer Ø9.0 x 18 x 25	WENG-BUS-1395	4
3	M8 x 50 Countersink Cap Screw A2-70	WFST-I10642SS-M08x50	4
4	Plain Washer M8 SS	WFST-I7089SS-16x08.0	4
5	M8 Nylock Nut A2-70	WFST-D985SS-M08	4

TOOLS REQUIRED

- Allen Key Nr. 5
- Socket Nr. 13
- Socket Wrench



Install Time
10 min

Preparation:

Read the instruction carefully before installation. Ensure that all parts listed in this document are included in the package.
Park the vehicle on a level hard surface in a sufficiently lit and ventilated work environment. Use only appropriate tools and equipment.
Disconnect the battery whenever working on the electrical system.

Installation:

Reconnect all connectors, clips and parts removed during the installation in accordance with the vehicle manufacturer specification
Secure all threads, unless otherwise specified with medium-strong liquid thread locker. Tighten all fasteners in accordance with the vehicle specification and / or according to DIN/ISO specification.
Replace all parts and hardware removed for installation according the vehicle specifications.

Functionality Check:

Once the installation is complete, ensure that no moving parts, wire or fuel hoses are pinched or obstructed in any way. Ensure the normal functionality of the vehicle. Attach and secure all cables and connectors correctly.

General:

If required register installed accessories in the vehicle document with appropriate authorities.

Disclaimer:

Instructions are set out as accurately as possible. There are currently no legal requirements for correctness. Technical issues may vary and are subject to change. Brightwing Technologies or any of its subsidiaries will not be liable for any damages, direct or indirect, that may arise from fitting accessories. For more see www.motorradical.co.za.

TORQUE CHART

A2 or A4 Stainless Steel	Lubricated (N-m)	0.9	2.3	4.6	7.8	-	19.1	38
	Dry (N-m)	1	2.6	5.1	8.7	-	21.2	42
Property Class	Bolt Diameter (mm)	3	4	5	6	7	8	10

MOUNTING

1. Place the Spacers (Part 2) into the indicated holes on the rear carrier of the motorcycle.

NOTE: ENSURE THAT THE ORIENTATION OF THE SPACERS ARE CORRECT.



2. Refer to the picture (right) for an indication of how the Spacers must be placed.



3. Place the Luggage Rack (Part 1) on top of the Spacers and align the holes with the spacer.

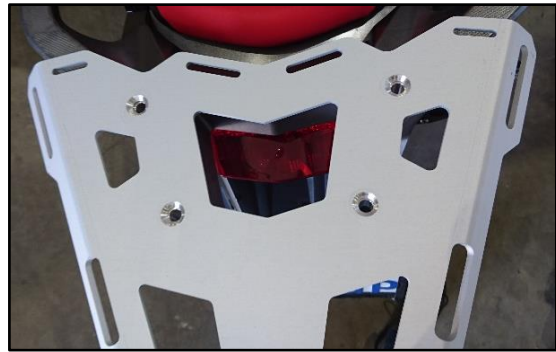

4. Insert the 4 x M8x50 Countersink Cap Screws (Part 3) as indicated into the holes in the Luggage Rack. Ensure that the fasteners are through the Spacers and the rear carrier.

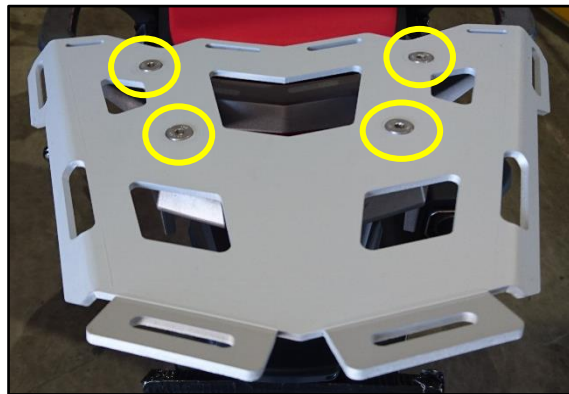

5. Using the below Fastening Kit securely fasten the Africa Twin Luggage Plate to the rear carrier of the motorcycle.

NOTE: DO NOT OVER TIGHTEN.



Fastening Kit:

Description	Qty	Torque
M8x 50 Countersink	4	21.2 N.m
M8 Washer	4	-
M8 Nylock Nuts	4	-



6. Refer to the picture for completed installation.

