

Accessory installation is the responsibility of the customer. Motorcycle Adventure Products and Hepco & Becker accept no responsibility for matters arising from the use of these recommendations.



Web Site: [www.hepco-becker.com.au](http://www.hepco-becker.com.au)

### Additional Information

#### All ALU series Cases

**PLEASE READ & TAKE NOTE OF ...**

The H&B supplied Service information! In addition, here is some 'local' information that we feel you should be aware of!

## GENERAL INFORMATION

- 1. It is the rider's responsibility to always ensure that their luggage is firmly locked to the motorcycle before riding off!**



**Test It Properly!!**

- 2. Test the lock catch by attempting to open it!** (Shown above) to ensure that the lock has been correctly engaged.



**X**



**✓**

Hepco & Becker are distributed in Australia & New Zealand by Motorcycle Adventure Products

For more information of this or any other product please contact on:

LANDLINE: +61 7 3139 0387 or

E-MAIL: [info@motorcycleadventure.com.au](mailto:info@motorcycleadventure.com.au)

Accessory installation is the responsibility of the customer. Motorcycle Adventure Products and Hepco & Becker accept no responsibility for matters arising from the use of these recommendations.

### 3. Mounting the Lock Plates to your frames

The H&B Lock Plate is spaced out by two tapered plates (per side) and is bolted to the two lugs on the frame by 4 M6x25 bolts supplied separately with the cases & plates.

**TIP!**

*The cast "V" section faces outward from the motorcycle.*

*The 4 M6x16 bolts supplied in the frame kit are spare.*

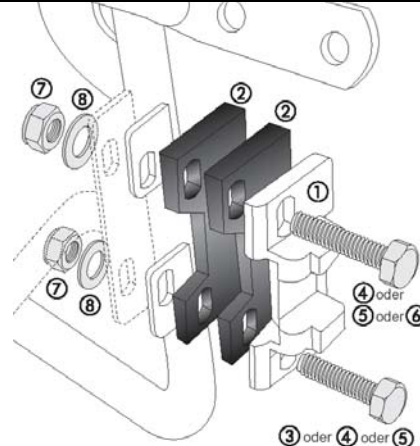

Initially tighten the bolts to 'finger tight', do a test fit of the pannier to align the lock & plate, remove pannier and tighten fully.

### 4. Attaching the Side Case to your frames

Present the side of the case so that the footing on the cases inner side rests ON TOP OF the lower loop of the frame tubing.

The front of the case has a U shape receptacle that you now slide onto the vertical front tube of the frame loop, ensuring that it (the U receptacle of the pannier) is fully seated into the front tube.

Now push/ swing the rear of the case in ensuring the molding & guides on the cases fully seat into the parallelogram of the frame loop.

Hepco & Becker are distributed in Australia & New Zealand by Motorcycle Adventure Products

For more information of this or any other product please contact on:

LANDLINE: +61 7 3139 0387 or

E-MAIL: [info@motorcycleadventure.com.au](mailto:info@motorcycleadventure.com.au)

**Accessory installation is the responsibility of the customer.  
Motorcycle Adventure Products and Hepco & Becker accept no responsibility  
for matters arising from the use of these recommendations.**

Now close the claw lock whilst keeping the key in the “Open” position whilst doing so! Ensure it goes over-centre) over the lock plate on frame, lock it (key turned to “Close”) & remove key & test correctly locked!

**5. Attaching the Top Case to your H-B rear Rack**

Lay the top case on the rear rack & ensure that it is sitting **CENTRALLY** on the rear rack (the H-B sticker on the front marks the centre).

Now push the top case forward until the front mounting lug (on the top case’s front) is fully engaged around the front loop of the rack (it moulds to the tube)

Now engage the claw lock underneath the case, and hook it over the flat section of the rear rack’s tubing again, ensuring it is central!

With the key in the “Open” position, close the lock (it goes over centre) then turn the key to closed & remove **NOW test the lock is really shut~!**

**ALU Racks** – If already have one & want to fit ALU series, the front loop needs to be changed – contact us!

**Tube Racks** – The width of a tube rack can vary with the bike so we strongly recommend the guides supplied with the top case be properly installed! (these look like little door stops)

**Hepco & Becker are distributed in Australia & New Zealand by Motorcycle Adventure Products**

**For more information of this or any other product please contact on:**

**LANDLINE: +61 7 3139 0387 or**

**E-MAIL: [info@motorcycleadventure.com.au](mailto:info@motorcycleadventure.com.au)**

**Accessory installation is the responsibility of the customer. Motorcycle Adventure Products and Hepco & Becker accept no responsibility for matters arising from the use of these recommendations.**

**6. Locking the Case Lids**

The case lock (hold's the case to bike) key can only be removed in the "Close" position. However the lid latch key can be withdrawn in BOTH "Open" & "Closed"! Make sure the cases are secure before leaving bike un-attended!

**7. Fitting Back Rests**

Each back rest comes with a drilling template for your case, please ensure you align it correctly before drilling & that also you insert the bolts upward from the inside

**8. Protecting the cases – ALU Series**

All H&B Panniers have side cases liner bags (as options) to assist carrying items inside the cases and easy removal. With ALU Standard single skinned series, "whilst are very ruggedly built", 'pin dint' damage might occur when large objects with sharp edges etc are loosely packed into the pannier allowing them to bounce around.

To this end we recommend you consider using a liner bag, OR consider lining the inside of the pannier with a good foam later (say 3mm) on the bottom, sides & underside of the lid. This can be affixed using contact cement (sparingly)

**Hepco & Becker are distributed in Australia & New Zealand by Motorcycle Adventure Products**

**For more information of this or any other product please contact on:**

**LANDLINE: +61 7 3139 0387 or**

**E-MAIL: [info@motorcycleadventure.com.au](mailto:info@motorcycleadventure.com.au)**

Accessory installation is the responsibility of the customer.  
Motorcycle Adventure Products and Hepco & Becker accept no responsibility  
for matters arising from the use of these recommendations.

## 9. Fitting the case Lid Loops – ALU Series



The handles fit to the lid, nylon washer's uppermost, metal strap & nyloc nut & washers below (on the underside)!

## 10. Key Numbers – All panniers

HB Tumblers are not numbered, only keys are numbered. Please record your key number in a safe place so that if you loose both keys we can easily supply new ones.

11. Do read the operation advice [red sheet] included in your case and "***Please be aware of the speed and load limitations***" stated within!

***Now with the luggage correctly fitted to your motorcycle, go & enjoy the ride!***

Hepco & Becker are distributed in Australia & New Zealand by Motorcycle Adventure Products

For more information of this or any other product please contact on:

LANDLINE: +61 7 3139 0387 or

E-MAIL: [info@motorcycleadventure.com.au](mailto:info@motorcycleadventure.com.au)