

Motorschutzbügel Kawasaki VN 900 custom/Vulcan

Artikel-Nummer:
501.221 00 02 chrom

Seitenkoffer
Topcases
Gepäckträger
Lock it System
Softbags
Aluminiumkoffer
Lederkoffer
Schutzbügel
Hauptständer
Chopper-Parts
Quad-Parts
Accessoires



Montageanleitung

Der Bausatz umfaßt die folgenden Teile:

Stück	Bestellnr.	Bezeichnung
1	700.511HB	Motorschutzbügel links
1	700.512HB	Motorschutzbügel rechts
1	702.263HB	Versteifungsstrebe
1	151.044	Inbusschraube M 10 x 1,25 x 80
1	151.042	Inbusschraube M 10 x 1,25 x 90
2	150.938	Linsenkopfschrauben M 8 x 20
2	150.810	U-Scheiben ø8,4
2	151.045	Karoseriescheiben ø10,5 x ø30 x 2,5



**Nach der Montage alle Verschraubungen auf festen Sitz kontrollieren!
Bitte beachten Sie unsere beigegefügt Serviceinformationen.**

Weiteres Zubehör:

Packtaschenhalter	Art.-Nr. 625.2501	Kofferträger chrom	Art.-Nr. 650.2501 00 02
Gepäckbrücke chrom	Art.-Nr. 650.2501 01 02	Twinlight-Set	Art.-Nr. 400.2502
Sissybar mit Gepäckbrücke	Art.-Nr. 611.217	Sissybar ohne Gepäckbrücke	Art.-Nr. 600.217



Hepco & Becker GmbH
An der Steinmauer 6
D-66955 Pirmasens

Tel.: 06331 - 1453 - 100
Fax: 06331 - 1453 - 120
eMail: vertrieb@hepco-becker.de
www.hepco-becker.de



Montage

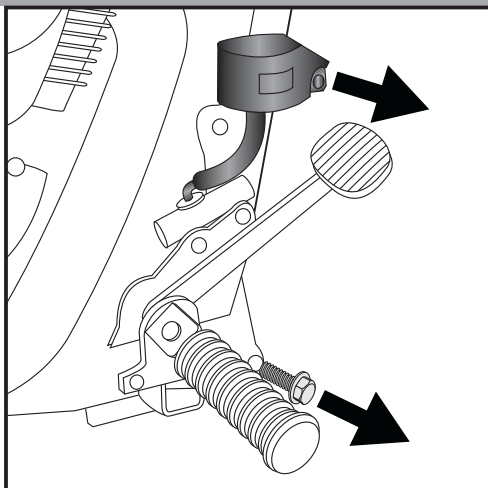

1

Vorbereitende Arbeiten:

Rechte Seite:

demontieren sie den Bremsflüssigkeitsbehälter.
Ebenfalls wird die vordere Schraube des Fußrasterhalters
herausgedreht.

Linke Seite:

am Fußrasterhalter werden beide Befestigungsschrauben
demontiert.

Tipp:

Schrauben Sie alle Teile an und lassen Sie die zugänglichen Schrauben etwas
locker. Nachdem alles montiert ist, werden alle Schrauben auf das entsprechende
Anzugsmoment angezogen. Dadurch wird sichergestellt, dass der Motorschutzbügel
Spannungsfrei angebaut ist. Dadurch ist eine lange Lebensdauer sichergestellt!

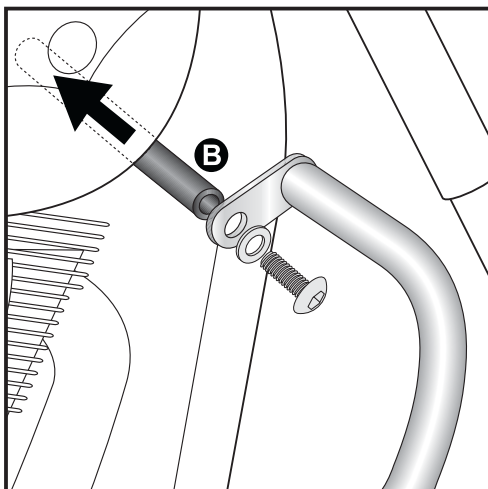

2

rechte Seite

Befestigung der Verfestigungsstrebe: **B**

Zuerst wird die Verfestigungsstrebe an der oberen langen Lasche
mit der Linsenkopfschraube M8 x 20 und einer U-Scheibe ø8,4
angeschraubt.

Platzieren Sie den Motorschutzbügel an den frei gemachten
Bohrungen, indem sie den Verfestigungsbügel zwischen Kühler und
Motor hindurch schieben.

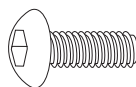

je 1x

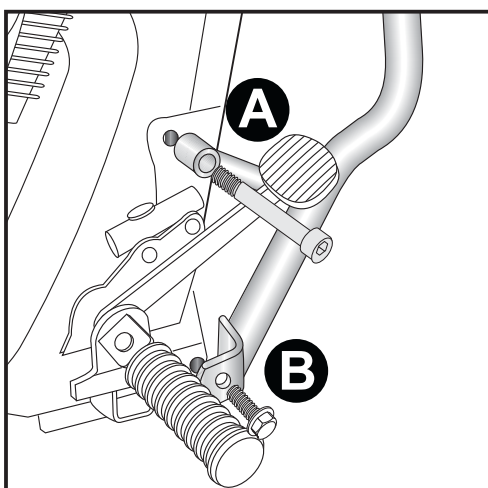

3

Montage des rechten Motorschutzbügels:

Mitte: **A**

die Inbusschraube M10 x 1,25 x 80 wird in die Gewindebohrung
unterhalb des Bremsflüssigkeitsbehälters montiert.
Montieren Sie den Bremsflüssigkeitsbehälter wieder an.

Unten: **B**

mit der Originalschraube zusammen mit dem Fußrasterhalter.



1x



Montage

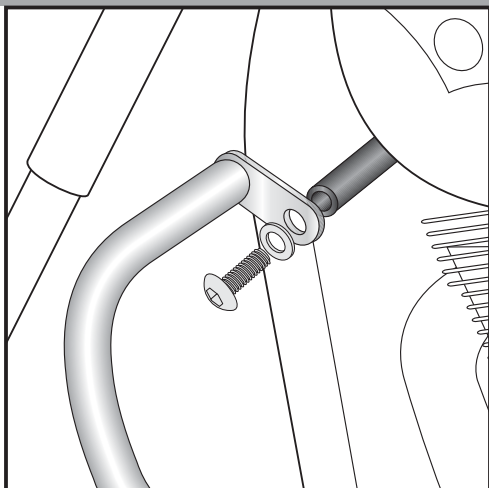

4 linke Seite

Montage des linken Motorschutzbügels:
Verschrauben Sie den Motorschutzbügel mit der Linsenkopfschraube M8 x 20 zusammen mit der U-Scheibe $\varnothing 8,4$ an der Versteifungsstrebe.

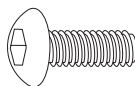

je 1x

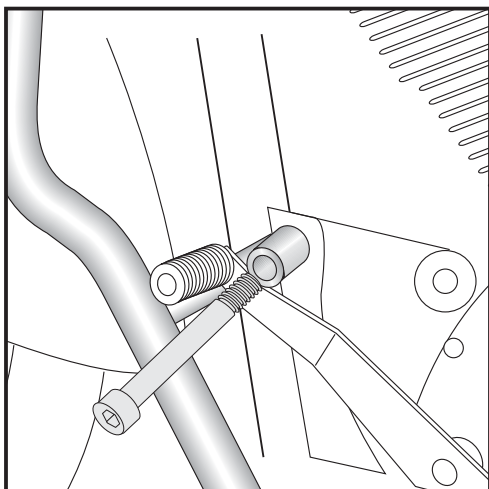

5 Montage des linken Motorschutzbügels Mitte:

mit der Inbusschraube M10 x 1,25 x 90 wird in die freie Gewindebohrung montiert.

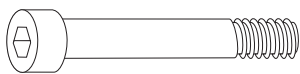

1x

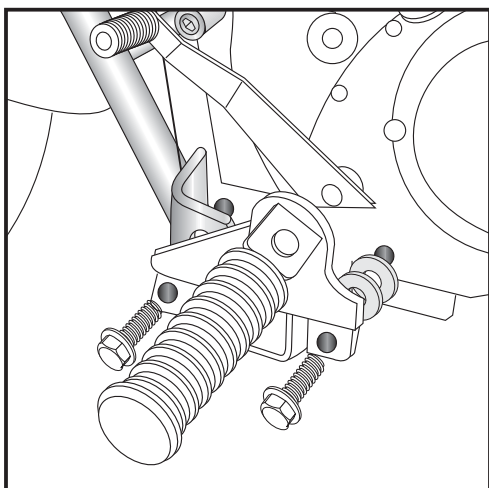

6 Montage des linken Motorschutzbügels Unten:

Verschrauben Sie den Motorschutzbügel indem sie unter die hintere Fußrasterhalterung die beiden Karosserie-scheiben $\varnothing 10,5 \times \varnothing 30 \times 2,5$ unterlegen und danach mit den Originalschrauben befestigen.

2x



**Engine guard
Kawasaki VN 900 custom/Vulcan**

**Item-No.
501.221 00 02 chrome**

Side cases
Top cases
luggage frames
Lock it system
Softbags
Aluminium luggage
Leather luggage
Protection bars
Center stands
Chopper parts
Quad parts
Accessories



Assembling instructions

The kit includes the following parts:

Quant	item no.	description
1	700.511HB	crash bar left
1	700.512HB	crash bar right
1	702.263HB	bracing bow
1	151.044	allen screw M 10 x 1,25 x 80
1	151.042	allen screw M 10 x 1,25 x 90
2	150.938	filister headscrew M 8 x 20
2	150.810	washer ø8,4
2	151.045	body washer ø10,5 x ø30 x 2,5



Control all screw connections after the assembling for tightness!

Please notice our enclosed service information.

All screws, bolts and nuts should be checked after driving the first 50 km to ensure that all are tightened to the proper torque.

Medium strength liquid thread-locker (i.e., „Locktite“) should be used to secure all screws, bolts, and nuts.

Also available:

Leather bag holder 625.2501
Rear rack chrome 650.2501 01 02
Sissybar with rear rack 611.217

Side carrier chrome 650.2501 00 02
Twinlight-Set 400.2501
Sissybar without rear rack 600.217



**Hepco & Becker GmbH
An der Steinmauer 6
D-66955 Pirmasens
Germany**

**Tel.: +49 6331 - 1453 - 100
Fax: +49 6331 - 1453 - 120
eMail: vertrieb@hepco-becker.de
www.hepco-becker.de**

Engine guard
Kawasaki VN 900 custom/Vulcan

Item-No.
501.221 00 02 chrome

Side cases
Top cases
luggage frames
Lock it system
Softbags
Aluminium luggage
Leather luggage
Protection bars
Center stands
Chopper parts
Quad parts
Accessories



Assembling instructions

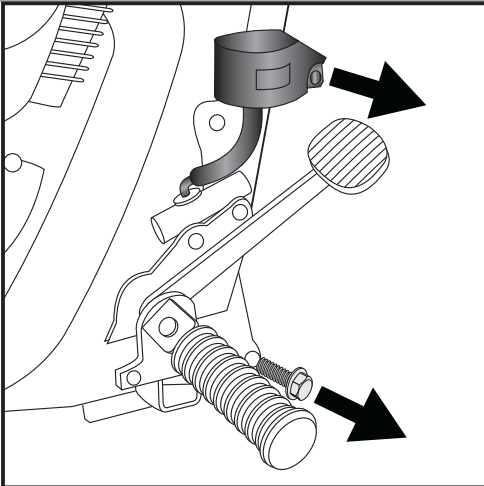

1

Preparing:

Right side:

Unscrew brake fluid container.

Unmount front screw of the footrest bracket.

Left side:

Unmount both screws of the footrest bracket.

Tip:

Fit all parts and screw on not too strong.

After mounting all parts, the screws should be tightened to the torque specified.

This guarantees, that the kit is mounted without tension.

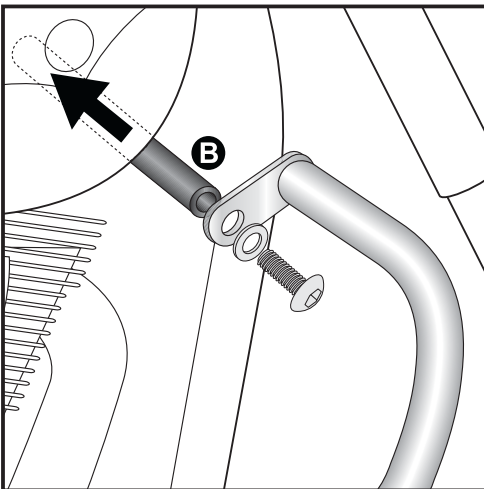

2

right side

Fastening of the bracing bow: **B**

Fix the bracing bow to the right side of the crash bar with filister head screw M8 x 20 and washer $\varnothing 8,4$.

Move the crash bar with the bracing bow from the right to the left side, between cooler and engine block.

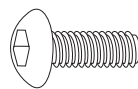

each 1x

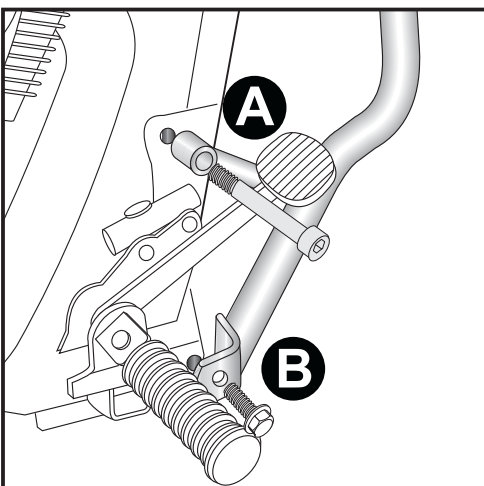

3

Fastening of the crash bar right:

Middle: **A**

with allen screw M10 x 1,25 x 80 in the free threaded hole below the brake fluid container

Mount brake fluid container.

Bottom: **B**

together with the footrest bracket with original screw



1x

Luggage ideas.

2

Engine guard
Kawasaki VN 900 custom/Vulcan

Item-No.
501.221 00 02 chrome

Side cases
Top cases
luggage frames
Lock it system
Softbags
Aluminium luggage
Leather luggage
Protection bars
Center stands
Chopper parts
Quad parts
Accessories



Assembling instructions

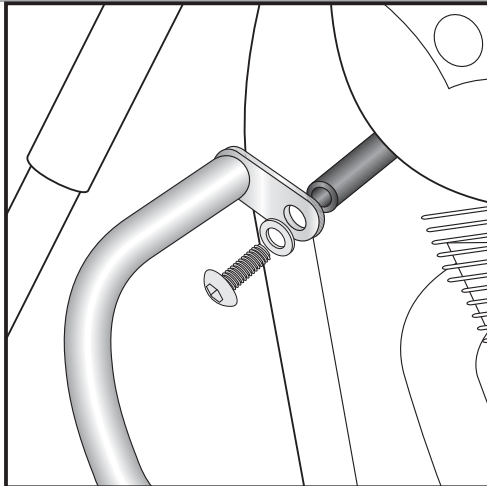

4 left side

Fastening of the bracing bow:

Fix the bracing bow to the left side of the crash bar with filister head screw M8 x 20 and washer $\varnothing 8,4$.

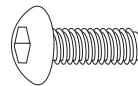

each 1x

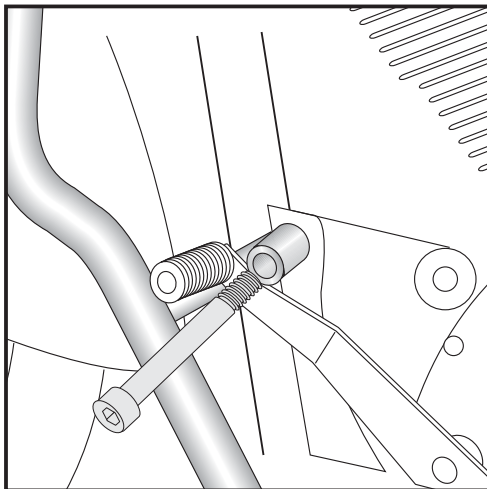

5 Fastening of the crash bar left middle: with allen screw M10 x 1,25 x 90.



1x

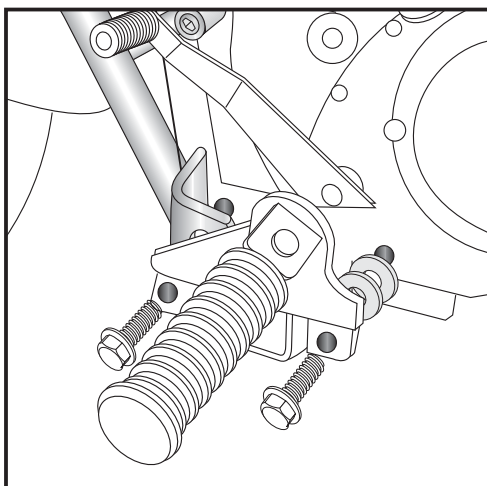

6 Fastening of the crash bar left bottom: Sandwich the two body washers $\varnothing 10,5 \times \varnothing 30 \times 2,5$ under the rear screw connection of the footrest bracket. Fix the crash bar with original screw.

2x

