

Motorschutzbügel
Suzuki GSF 1250 Bandit
ab Bj. 07

Art.-Nr.: 501.326 00 01 schwarz

Seitenkoffer
Topcases
Gepäckträger
Lock it System
Softbags
Aluminiumkoffer
Lederkoffer
Schutzbügel
Hauptständer
Chopper-Parts
Quad-Parts
Accessoires



Montage

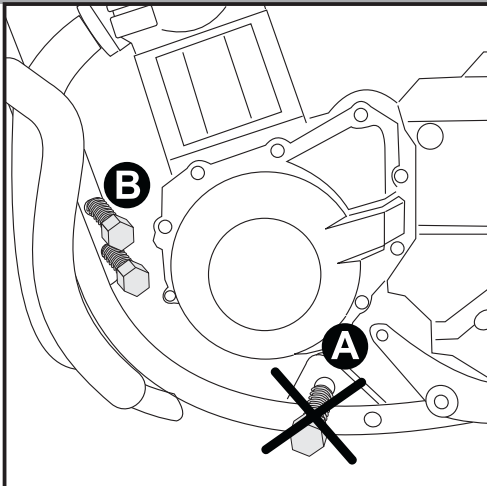

1 linke Seite

Vorbereitung:

Demontieren sie die Sechskantschraube (SW14) **A** unterhalb des Schalthebels. Diese Schraube entfällt.

Ebenfalls zu demontieren sind die beiden Sechskantschrauben (SW 12) **B** am linken Rahmenunterzug vor dem Motor.

Die Originalschrauben werden wieder verwendet.

Tipp:

Schrauben sie alle Teile an und lassen sie die zugänglichen Schrauben etwas locker. Nachdem alles montiert ist, werden alle Schrauben auf das entsprechende Anzugsmoment angezogen. Dadurch wird sichergestellt, dass das Produkt spannungsfrei angebaut ist. So ist eine lange Lebensdauer sichergestellt!

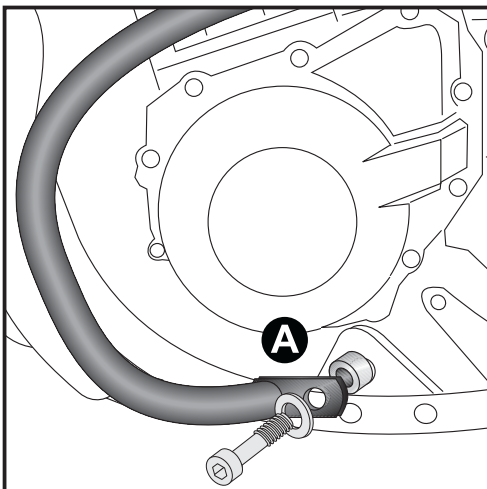

2

Montage des linken Motorschutzbügels:

Nun montieren sie mit der Inbusschraube M10 x 1,25 x 60 und U-Scheibe $\varnothing 10,5$ die untere Befestigungslasche am Rahmen an und platzieren zwischen Lasche und Rahmen die Distanz $\varnothing 20 \times \varnothing 11 \times 13$ mm.



je 1x

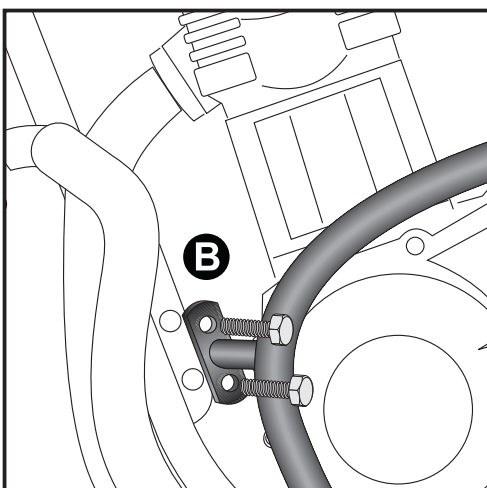

3

Montage des linken Motorschutzbügels:

Montieren sie den Motorschutzbügel links am Rahmenunterzug vor dem Motor mit den beiden Originalschrauben (SW 12).

Motorschutzbügel
Suzuki GSF 1250 Bandit
ab Bj. 07

Art.-Nr.: 501.326 00 01 schwarz

Seitenkoffer
Topcases
Gepäckträger
Lock it System
Softbags
Aluminiumkoffer
Lederkoffer
Schutzbügel
Hauptständer
Chopper-Parts
Quad-Parts
Accessoires



Montage

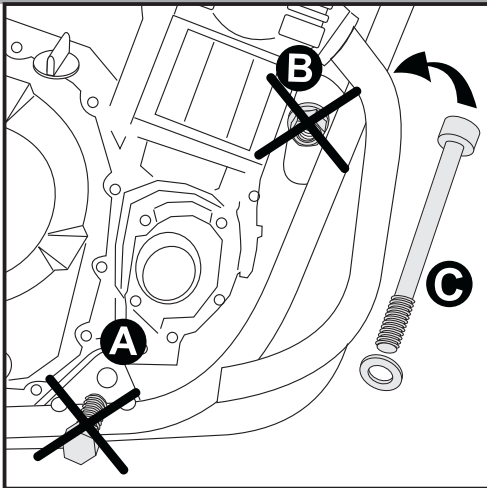

4 rechte Seite

Vorbereitung:

Demontieren sie die Sechskantschraube (SW14) unterhalb des Fußbremshebels. **A** Diese Schraube entfällt.

Anschließend lösen sie am rechten Rahmenunterzug (vor dem Motor) die Mutter (SW 14) **B** und ziehen sie die Schraube heraus.

Achtung, Schraube kann sich mitdrehen, bitte gegenhalten!

Ersetzen sie diese mit der mitgelieferten Inbusschraube M10x1,25x220 **C** inkl. der U-Scheibe $\varnothing 10,5$.

Schraube wird von links nach rechts durchgeschoben.

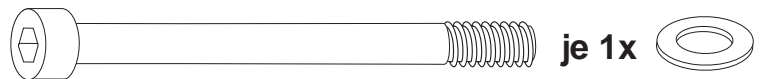

je 1x

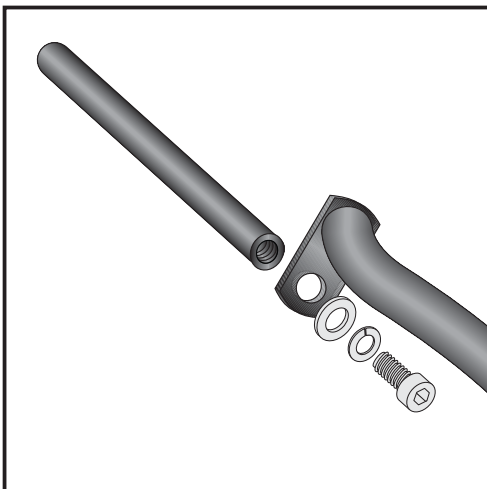

5 Montieren der Verstärkungsstrebe:

Montieren sie am Motorschutzbügel rechts die Verstärkungsstrebe mit der Inbusschraube M8 x 16, der U-Scheibe $\varnothing 8,4$ und dem Sprengling $\varnothing 8,4$.

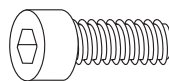

je 1x

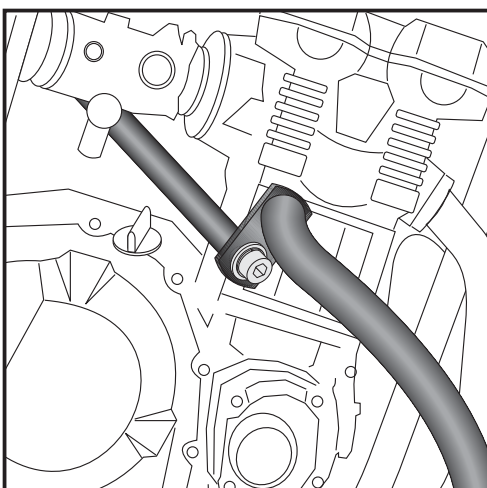

6 Nun fügen sie diese an das Motorrad indem sie zunächst die Verstärkungsstrebe hinter dem Motor hindurch schieben.

Motorschutzbügel
Suzuki GSF 1250 Bandit
ab Bj. 07

Art.-Nr.: 501.326 00 01 schwarz

- Seitenkoffer
- Topcases
- Gepäckträger
- Lock it System
- Softbags
- Aluminiumkoffer
- Lederkoffer
- Schutzbügel
- Hauptständer
- Chopper-Parts
- Quad-Parts
- Accessoires



Montage

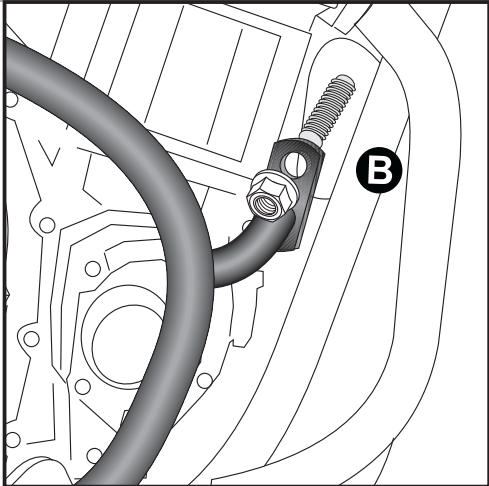

7 rechte Seite

Montage des rechten Motorschutzbügels:
Führen sie jetzt den rechten Motorschutzbügel über das überstehende Schraubenende aus Montageschritt 4 und drehen sie die Originalmutter wieder auf. Gegenhalten!

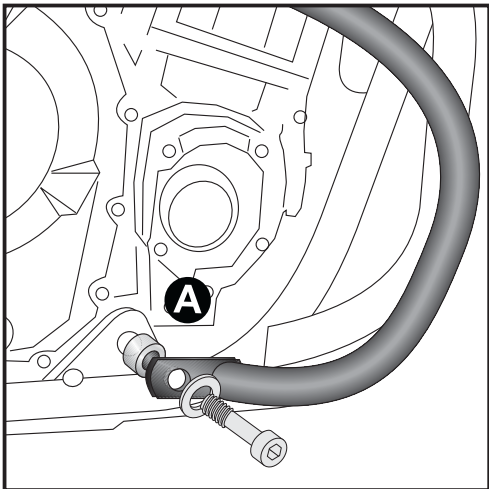

8

Montage des rechten Motorschutzbügels:
Nun montieren sie mit der Inbusschraube M10 x 1,25 x 60 und U-Scheibe $\varnothing 10,5$ die untere Befestigungs-lasche am Rahmen und setzen zwischen Lasche und Rahmen die Distanz $\varnothing 20 \times \varnothing 11 \times 11$ mm.

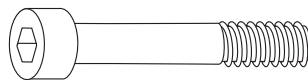

je 1x

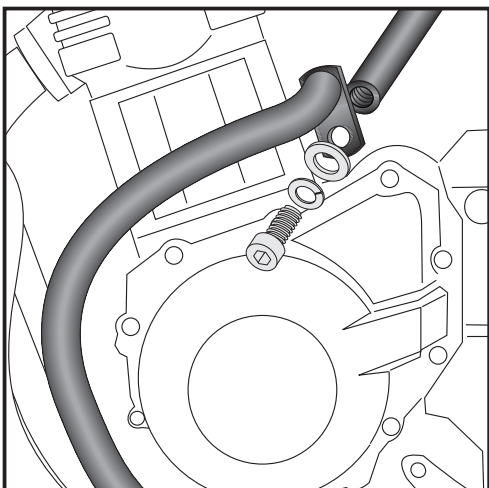

9

Zuletzt wird die Versteifungstrebe mit dem Motorschutzbügel auf der linken Seite mit der Inbusschraube M8 x 16, der U-Scheibe $\varnothing 8,4$ und dem Sprengring $\varnothing 8,4$ verbunden.

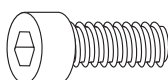

je 1x



**Motorschutzbügel
Suzuki GSF 1250 Bandit
ab Bj. 07**

Art.-Nr.: 501.326 00 01 schwarz

Seitenkoffer
Topcases
Gepäckträger
Lock it System
Softbags
Aluminiumkoffer
Lederkoffer
Schutzbügel
Hauptständer
Chopper-Parts
Quad-Parts
Accessoires



Montage

Stück	Bestellnr.	Bezeichnung
1	703.507HB	Motorschutzbügel links
1	703.508HB	Motorschutzbügel rechts
1	703.509HB	Versteifungsstrebe (M8 Innengewinde)
2	150.952	Inbusschraube M10 x 1,25 x 60
1	150.088	Inbusschraube M10 x 1,25 x 220
2	150.780	Inbusschrauben M8 x 16
3	150.811	U-Scheiben ø10,5
2	150.810	U-Scheibe ø8,4
2	150.805	Sprengring ø8,4
1	151.089	Distanz ø20 x ø11 x 13
1	151.090	Distanz ø20 x ø11 x 11

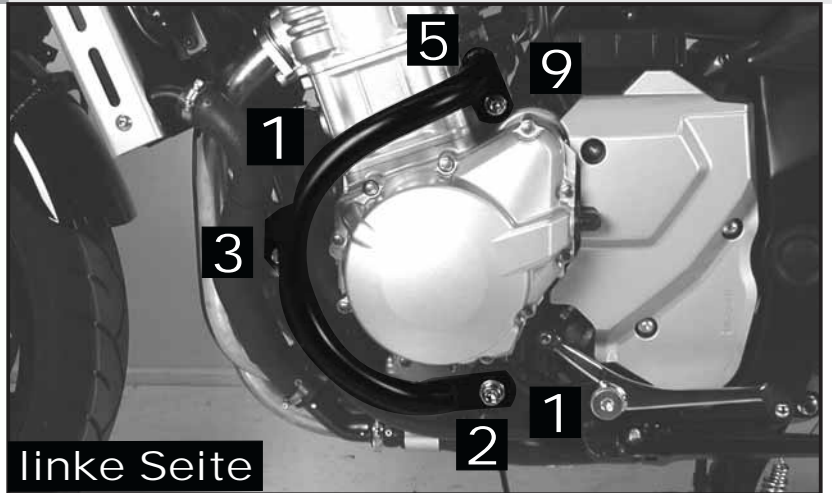

linke Seite

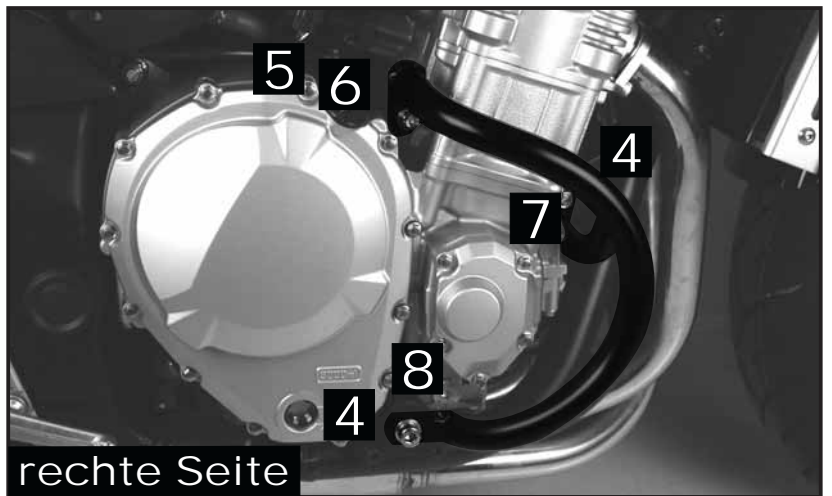

rechte Seite

Anzugsmomente des Motorradherstellers beachten!

Nach der Montage alle Verschraubungen auf festen Sitz kontrollieren!

Bitte beachten Sie unsere beigefügten Serviceinformationen.

Als weiteres Zubehör lieferbar:

650.3513 00 01 Kofferträger schwarz "Lock it System" (abnehmbar)

650.3513 01 01 Gepäckbrücke schwarz



**Hepco & Becker GmbH
An der Steinmauer 6**

D-66955 Pirmasens

Tel.: 06331 - 1453 - 100

Fax: 06331 - 1453 - 120

eMail: vertrieb@hepco-becker.de

www.hepco-becker.de

Engine guard
SUZUKI GSF 1250 Bandit
from year of manufacture 2007

Item-No.
501.326 00 01 black

Side cases
Top cases
luggage frames
Lock it system
Softbags
Aluminium luggage
Leather luggage
Protection bars
Center stands
Chopper parts
Quad parts
Accessories



Assembling instructions

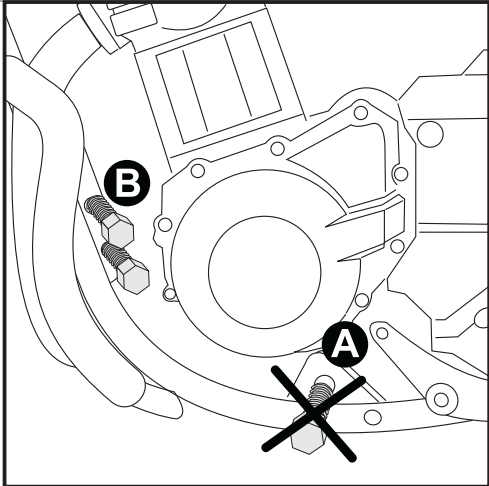

1 left side

Preparing:

Unmount the screw, marked **A** in the picture.

The screw is not needed any more.

Unmount the screws, marked **B** in the picture (at the frame in front of the engine.) They will be used again.

Tip:

Fit all parts and screw on not too strong.

After mounting all parts, the screws should be tightened to the torque specified.

This guarantees, that the kit is mounted without tension.

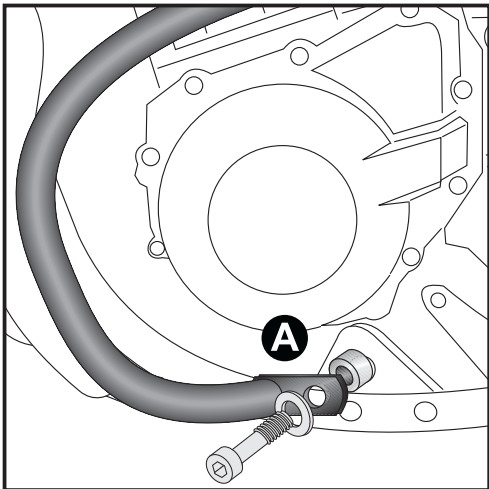

2

Fastening of the crash bar left:

with allen screw M10 x 1,25 x 60 and washer \varnothing 10,5.

Sandwich spacer \varnothing 20 x \varnothing 11 x 13 mm between frame and shackle.

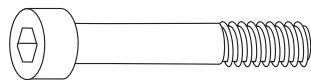

each 1x

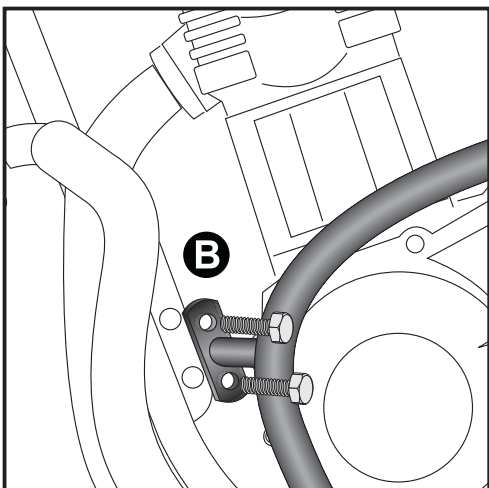

3

Fastening of the crash bar left front:

Fix the crash bar left in the free threaded holes with the original screws.

Engine guard
 SUZUKI GSF 1250 Bandit
 from year of manufacture 2007

Item-No.
 501.326 00 01 black

- Side cases
- Top cases
- luggage frames
- Lock it system
- Softbags
- Aluminium luggage
- Leather luggage
- Protection bars
- Center stands
- Chopper parts
- Quad parts
- Accessories



Assembling instructions

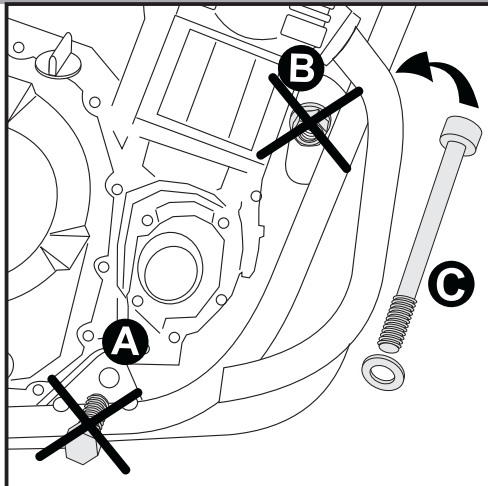

4 right side

Preparing:
 Unmount the screw, marked **A** in the picture.
 Unmount the nut at the frame in front of the engine. **B**
 Replace the original screw with allen screw M10x1,25x220 **C**
 and washer $\varnothing 10,5$.
 Push it through from left to right side.

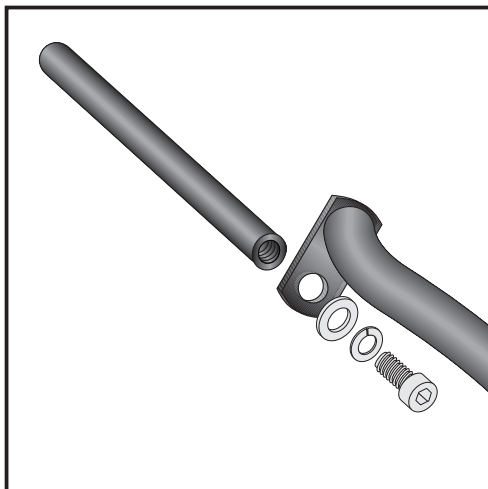
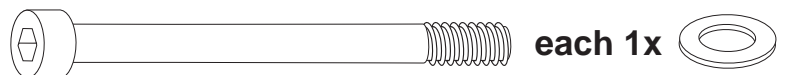

5 Fastening of the bracing bow:

Mount the bracing bow at the crash bar right with allen screw M8 x 16,
 washer $\varnothing 8,4$ and the lock ring $\varnothing 8,4$.

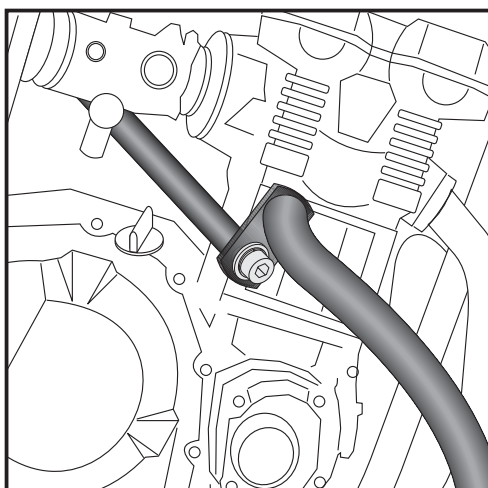

6 Move the bracing bow to the correct position behind the engine.

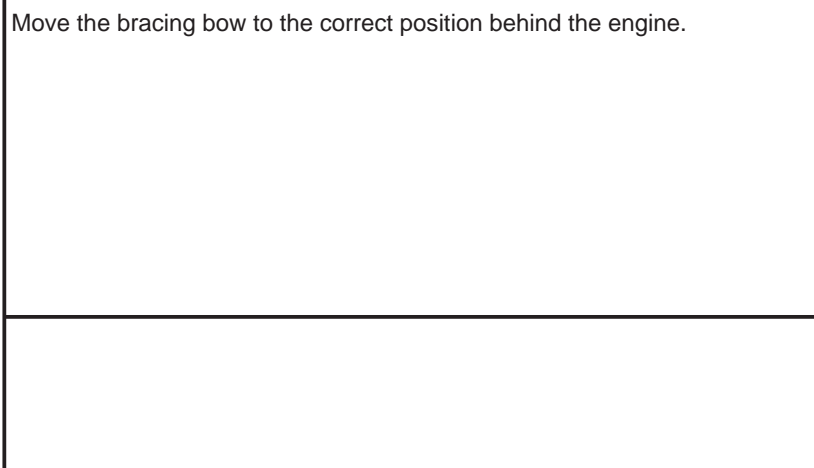

Engine guard
SUZUKI GSF 1250 Bandit
 from year of manufacture 2007

Item-No.
 501.326 00 01 black

- Side cases
- Top cases
- luggage frames
- Lock it system
- Softbags
- Aluminium luggage
- Leather luggage
- Protection bars
- Center stands
- Chopper parts
- Quad parts
- Accessories



Assembling instructions

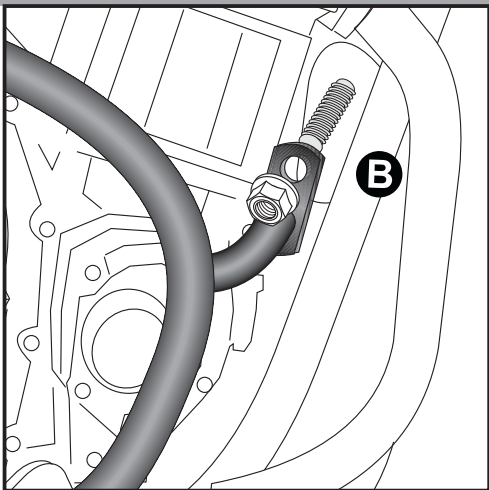

7 right side

Fastening of the crash bar right:
 Fix crash bar at the end of the screw mounted in step 4.
 Use original nut. Hold the screw at the left side.

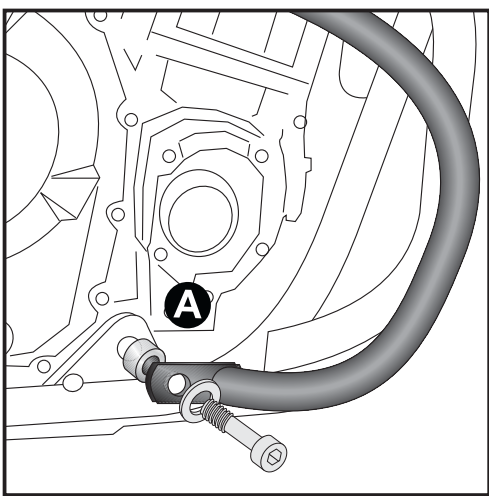

8

Fastening of the crash bar right:
 with allen screw M10 x 1,25 x 60 and washer ø10,5.
 Sandwich spacer ø20 x ø11 x 11 mm.

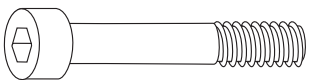

each 1x

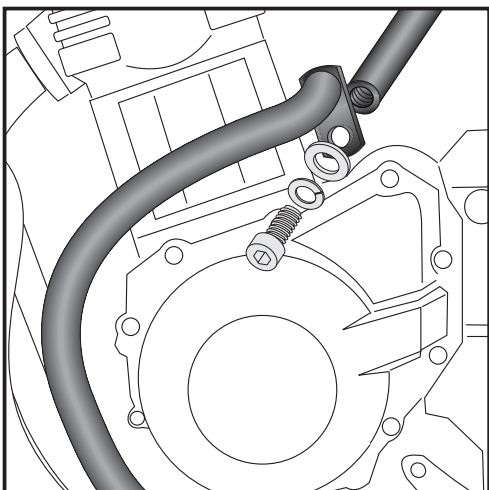
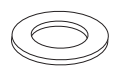

9

Fastening of the crash bar left:
 Fix the bracing bow with the crash bar with allen screw M8 x 16, washer ø8,4 and lock ring ø8,4.

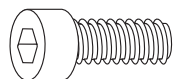

each 1x

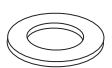

Engine guard
SUZUKI GSF 1250 Bandit
 from year of manufacture 2007

Item-No.
 501.326 00 01 black

- Side cases
- Top cases
- luggage frames
- Lock it system
- Softbags
- Aluminium luggage
- Leather luggage
- Protection bars
- Center stands
- Chopper parts
- Quad parts
- Accessories



Assembling instructions

Stück	Bestellnr.	Bezeichnung
1	703.507HB	crash bar left
1	703.508HB	crash bar right
1	703.509HB	bracing bow
2	150.952	allen screw M10 x 1,25 x 60
1	150.088	allen screw M10 x 1,25 x 220
2	150.780	allen screw M8 x 16
3	150.811	washer ø10,5
2	150.810	washer ø8,4
2	150.805	lock ring ø8,4
1	151.089	spacerø20 x ø11 x 13
1	151.090	spacerø20 x ø11 x 11

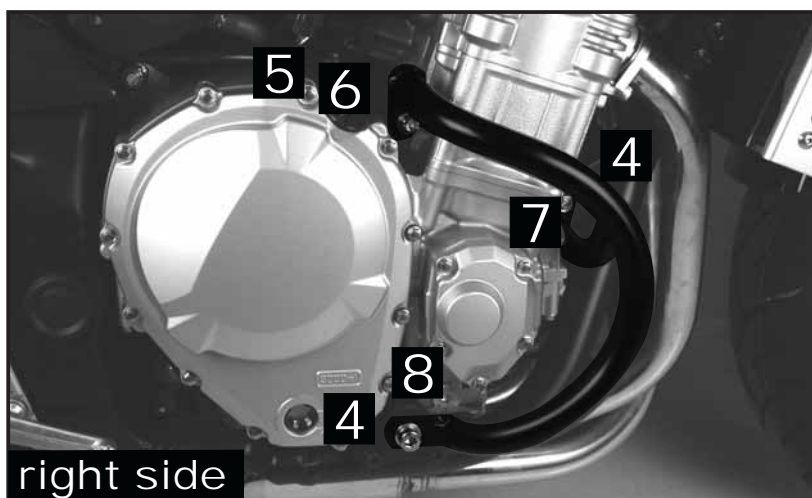
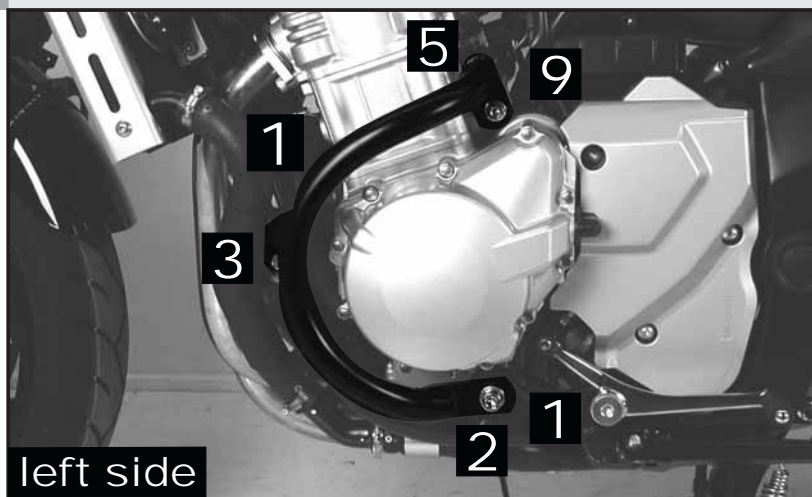

Control all screw connections after the assembling for tightness!

Please notice our enclosed service information.

All screws, bolts and nuts should be checked after driving the first 50 km to ensure that all are tightened to the proper torque.

Medium strength liquid thread-locker (i.e., „Locktite“) should be used to secure all screws, bolts, and nuts.

Also available:

Side carrier 650.3513 00 01 black, "Lock it System" (removable)

Rear rack 650.3513 01 01 black



Hepco & Becker GmbH
 An der Steinmauer 6
 D-66955 Pirmasens
 Germany

Tel.: +49 6331 - 1453 - 100

Fax: +49 6331 - 1453 - 120

eMail: vertrieb@hepco-becker.de

www.hepco-becker.de