

C-Bow Taschenhalter

MOTO GUZZI
California 1400 Custom

Artikel Nr.:
630544 00 02 chrom



Montage

Der Bausatz umfaßt die folgenden Teile:

Stück	Bestellnr.	Bezeichnung	Stück	Bestellnr.	Bezeichnung
2	700007062	C – BOW chrom	2	151.170	Senkinbusschraube M8 x 45mm
1	700008320	Halteadapter rechts	8	150.916	Sechskantschraube M6 x 18mm
1	700008321	Halteadapter links	8	150.809	U – Scheibe Ø 6,4
2	150.787	Inbusschraube M8 x 45mm	2	150.810	U – Scheibe Ø 8,4
2	150.766	Inbusschraube M6 x 35mm	2	150.800	selbstsichernde Mutter M8



Anzugsmomente des Motorradherstellers beachten!
Nach der Montage alle Verschraubungen auf festen Sitz kontrollieren!
Bitte beachten Sie unsere beigefügten Serviceinformationen.

Weiteres Zubehör:

611544.0002 Sissybar mit Gepäckbrücke
600544.0002 Sissybar ohne Gepäckbrücke
650544.0102 Gepäckbrücke
501544 Motorschutzbügel



Hepco & Becker GmbH
An der Steinmauer 6
D-66955 Pirmasens
Tel.: 06331 - 1453 - 100
Fax: 06331 - 1453 - 120
eMail: vertrieb@hepco-becker.de
www.hepco-becker.de

C-Bow Taschenhalter

MOTO GUZZI
California 1400 Custom

Artikel Nr.:
630544 00 02 chrom



Montage

Vorbereitung:

Hinter dem Federbein die Originalschraube der Befestigung der Kunststoffverkleidung demontieren - diese entfällt.
Die Blinker verbleiben in der Originalposition.

1 Befestigung oben vorne links und rechts:
Hinter dem Federbein in den frei gemachten Gewinden.
Den Halteadapter mit der Inbusschraube M6x35mm verschrauben.

Noch nicht ganz festziehen

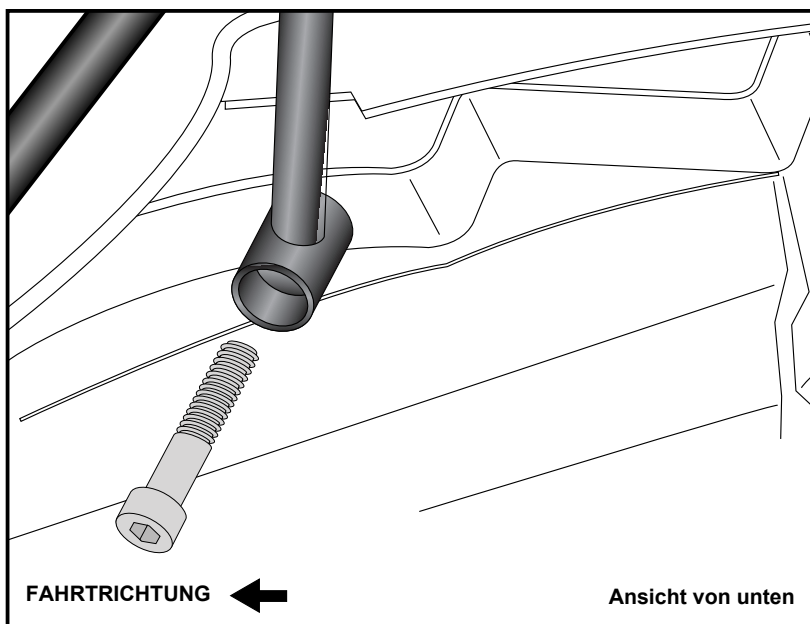
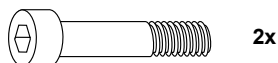

2 Befestigung oben hinten links und rechts:
An den hinteren freien Gewinden unterhalb des Kotflügels mit der Inbusschraube M8x45mm.

Noch nicht ganz festziehen.

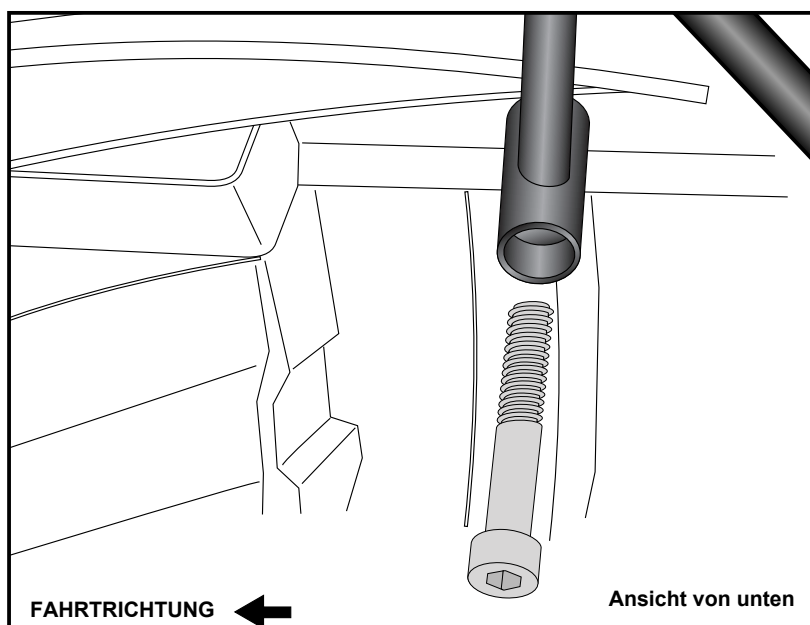
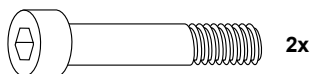

C-Bow Taschenhalter

MOTO GUZZI
California 1400 Custom

Artikel Nr.:
630544 00 02 chrom



Montage

3 Befestigung vorne unten links und rechts:
Die Originalschraube der Auspufftopf-
aufhängung demontieren - diese entfällt.
Anstelle der Originalschraube die
Senkschraube M8x45 durchstecken.
Auf das überstehende Gewinde von Innen
den Halteadapter montieren und mit der
selbtsichernden Mutter M8 mit U-Scheibe
Ø 8,4 verschrauben.

Nun alle Teile festziehen.

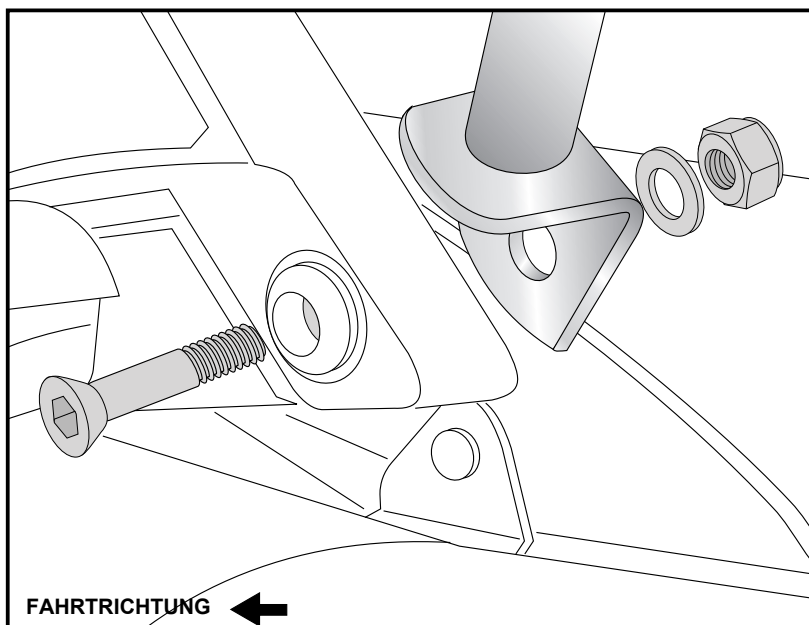
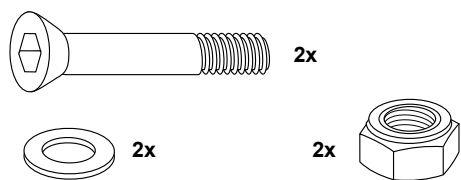

4 Montage der C-Bow an den Halteadapter
vorne links + rechts:
Dazu die Sechskantschrauben M6x16
und die U-Scheiben Ø6,4 verwenden.

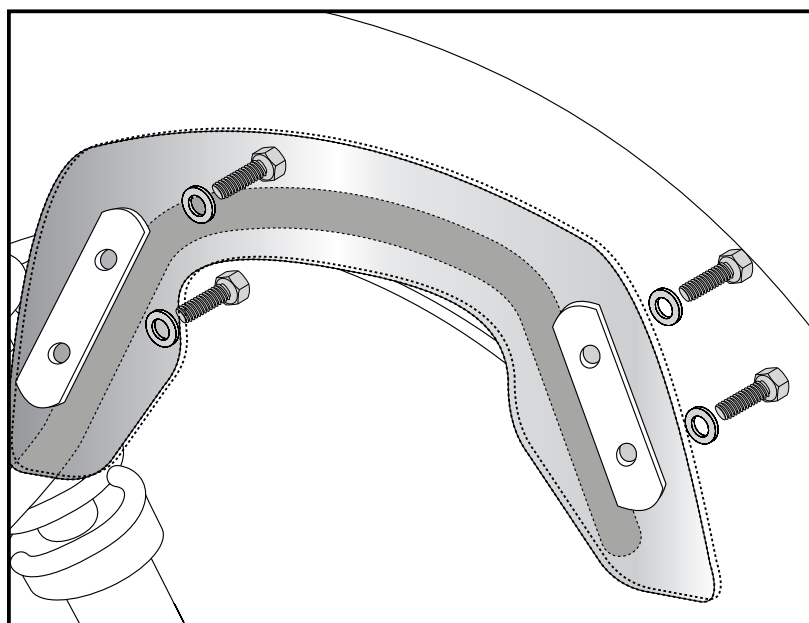

C-Bow Soft bag holder

MOTO GUZZI
California 1400 Custom

Item-no.:
630544 00 02 chrome



Assembling instructions

The kit includes the following parts:					
Quant	item no.	description	Quant	item no.	description
2	700007062	C – BOW chrome	2	151.170	countersunk screw M8 x 45mm
1	700008320	adapter right	8	150.916	countersunk screw M6 x 18mm
1	700008321	adapter left	8	150.809	washer Ø 6,4
2	150.787	allen screw M8 x 45mm	2	150.810	washer Ø 8,4
2	150.766	allen screw M6 x 35mm	2	150.800	self lock nut M8



Control all screw connections after the assembling for tightness!
Please notice our enclosed service information.

Other accessories:

611544.0002	Sissybar with rear rack
600544.0002	Sissybar without rear rack
650544.0102	Rear rack
501544	Engine guard



Hepco & Becker GmbH
An der Steinmauer 6
D-66955 Pirmasens
Tel.: +49 6331 - 1453 - 100
Fax: +49 6331 - 1453 - 120
eMail: vertrieb@hepco-becker.de
www.hepco-becker.de

C-Bow Soft bag holder

MOTO GUZZI
California 1400 Custom

Item-no.:
630544 00 02 chrome



Assembling instructions

Preparing:

Dismantle the original screw fastening the plastic fairing behind the strut - screw is obsolete.
The turn signals remain in their original position.

Fastening front top left + right:
behind the strut in the free threads.
Use allen screws M6 x 35mm.

Do not fully tighten yet.

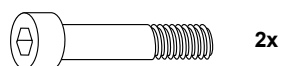

1

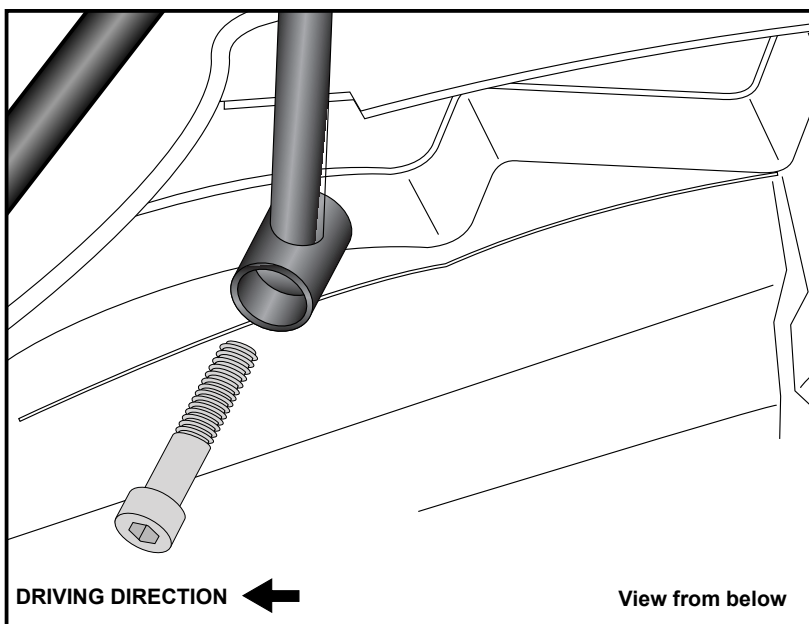

Fastening rear top left + right:
in the free threads under the fender.
Use allen screws M8 x 45mm.

Do not fully tighten yet.

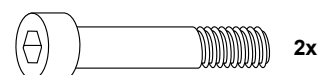

2

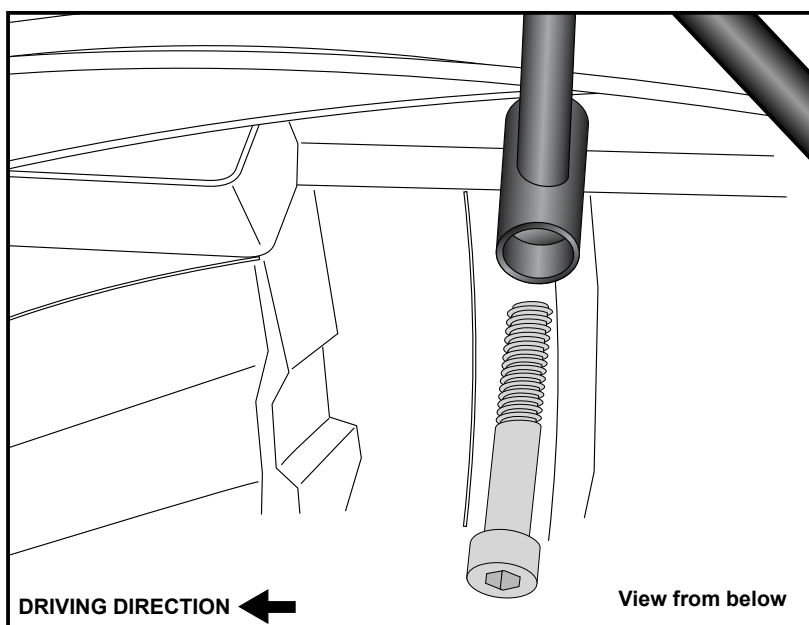

C-Bow Soft bag holder

MOTO GUZZI
California 1400 Custom

Item-no.:
630544 00 02 chrome



Assembling instructions

3 Fastening front bottom left + right:
Dismantle the original screw of the exhaust bolting - it is obsolete.
Instead use countersunk screw M8x45.
Fix the adapter at the back side with a self lock nut M8 and washer $\varnothing 8,4$.

Now screw on all nuts and bolts.

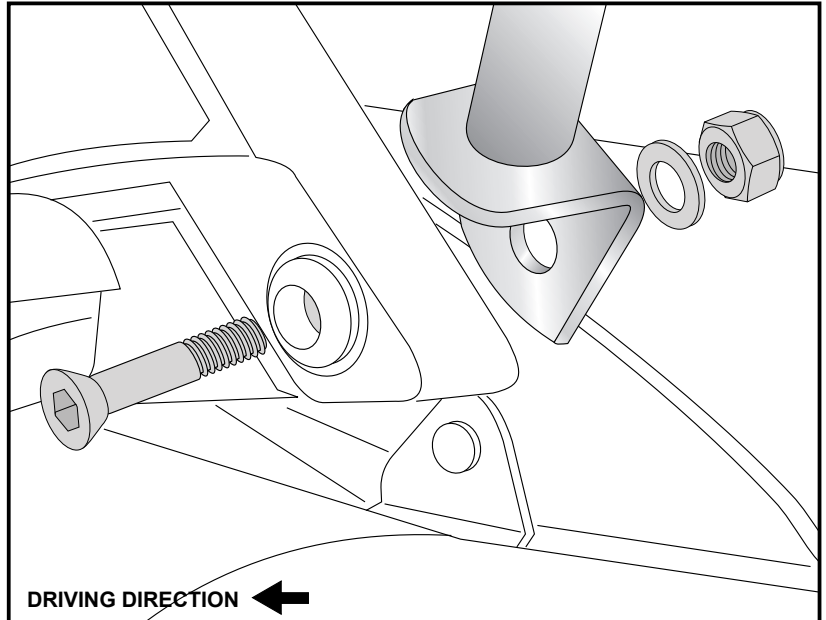
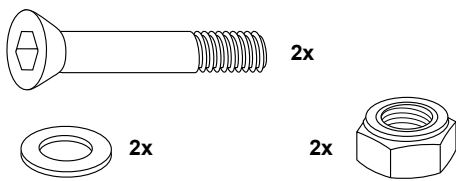

4 Fastening of the C-Bow to the adapters
left + right:
with hexagon bolts M6 x 16 and
washers $\varnothing 6,4$.

