

# C-Bow Taschenhalter

APRILIA Shiver 750  
bis Bj. 2009

APRILIA Shiver 750 GT

Artikel Nr.:  
**630752 schwarz**



## Montage

Der Bausatz umfaßt die folgenden Teile:

Stück	Bestellnr.	Bezeichnung
2	700007063	C-Bow schwarz
1	700007411	C-Bow Halteadapter links vorne
1	700007412	C-Bow Halteadapter links hinten
1	700007413	C-Bow Halteadapter rechts vorne
1	700007414	C-Bow Halteadapter rechts hinten
1	700006994	Adapterbügel unten
4	151.024	Senkinbusschrauben M6 x 20mm
2	150.765	Inbusschraube M6 x 30mm
2	150.783	Inbusschraube M8 x 25mm
2	150.784	Inbusschraube M8 x 30mm
8	150.915	Sechskantschraube M6 x 16mm
10	150.809	U-Scheibe Ø6,4
2	150.803	Tensilockmuttern M8

Die hinteren Blinker verbleiben  
in der Originalposition.

**Tip:**  
Ziehen sie alle zugänglichen Schrauben  
zuerst nur locker an. Nachdem alles montiert  
ist, werden die Schrauben dann auf das  
entsprechende Anzugsmoment festgezogen.  
Dadurch wird sichergestellt, dass das  
Produkt spannungsfrei angebaut ist.  
Schrauben zusätzlich mit Sicherungsmittel  
sichern. Anzugsmomente des Motorrad-  
herstellers beachten!



Anzugsmomente des Motorradherstellers beachten!  
Nach der Montage alle Verschraubungen auf festen Sitz kontrollieren!  
Bitte beachten Sie unsere beigefügten Serviceinformationen.



Hepco & Becker GmbH  
An der Steinmauer 6  
D-66955 Pirmasens  
Tel.: 06331 - 1453 - 100  
Fax: 06331 - 1453 - 120  
eMail: [vertrieb@hepco-becker.de](mailto:vertrieb@hepco-becker.de)  
[www.hepco-becker.de](http://www.hepco-becker.de)

# C-Bow Taschenhalter

APRILIA Shiver 750  
bis Bj. 2009

APRILIA Shiver 750 GT

Artikel Nr.:  
**630752 schwarz**



## Montage

**1** Befestigung des unteren Adapterbügels:  
Dieser verläuft quer zur Fahrtrichtung unterhalb des Auspufftopfes. Er wird von aussen mit den Inbusschrauben M6 x 30 sowie U-Scheiben ø6,4 verschraubt. Die Originalschrauben entfallen.

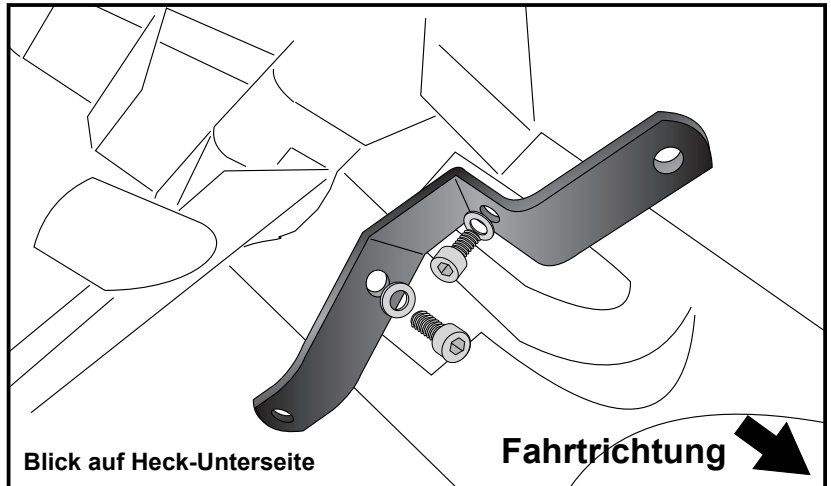

**2** Montage der Halteadapter links und rechts vorne:  
Befestigung hinter den Soziusfussrasten an den freien Gewindebohrungen mit den Senkinbusschrauben M6 x 20.

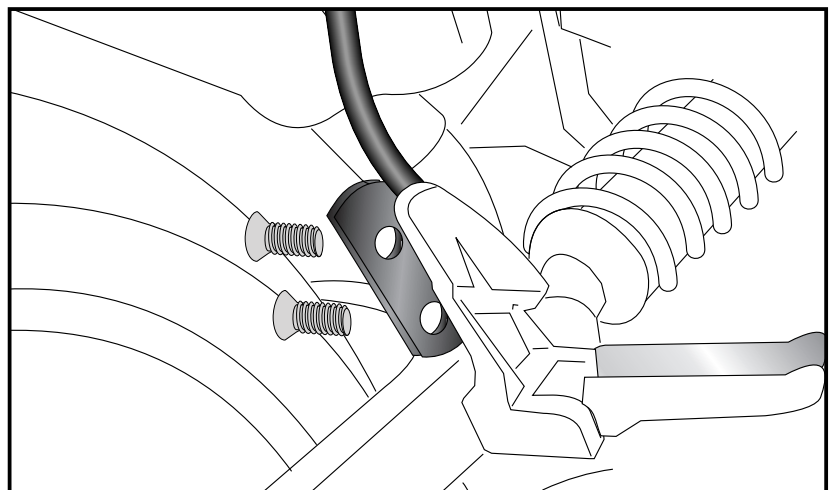
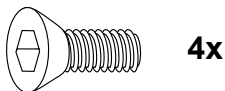

**3** Montage der Halteadapter links und rechts hinten:  
Befestigung über dem zuvor montierten unteren Haltebügel (Schritt 1) mit Inbusschrauben M8 x 25 und Tensilockmuttern M8 verwenden.

Wenn Alu-Rack und C-BOW kombiniert angebaut werden, Inbusschrauben M8 x 30mm verwenden.

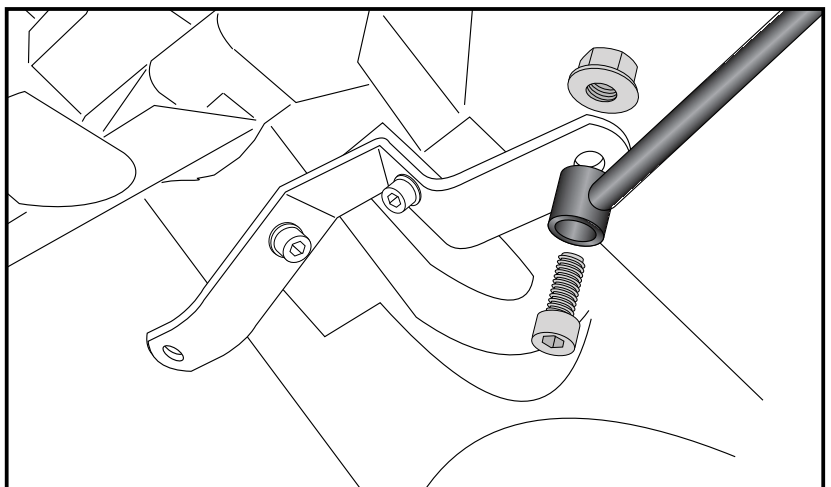

# C-Bow Taschenhalter

APRILIA Shiver 750  
bis Bj. 2009

APRILIA Shiver 750 GT

Artikel Nr.:  
**630752** schwarz



## Montage

Montage der C-Bow links + rechts:

Dazu die Sechskantschrauben M6x16  
und die U-Scheiben Ø6,4 verwenden.

Alle Teile korrekt ausrichten und die  
Verschraubungen festziehen.

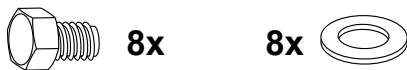

**4**

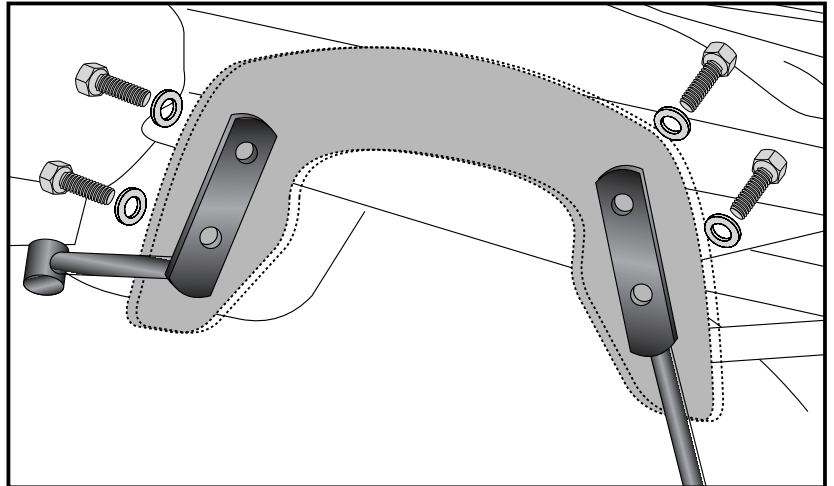

# C-Bow Soft bag holder

**APRILIA Shiver 750**

up to date of manufacture 2009

**APRILIA Shiver 750 GT**

Item-no.:

**630752 black**



## Assembling instructions

The kit includes the following parts:

Quant	item no.	description
2	700007063	C-Bow schwarz
1	700007411	C-Bow adapter left front
1	700007412	C-Bow adapter left rear
1	700007413	C-Bow adapter right front
1	700007414	C-Bow adapter right rear
1	700006994	adapter bow
4	151.024	countersunk head allen screw M6 x 20mm
2	150.765	allen screw M6 x 30mm
2	150.783	allen screw M8 x 25mm
2	150.784	allen screw M8 x 30mm
8	150.915	hexagon bolt M6 x 16mm
10	150.809	washer Ø6,4
2	150.803	tensilock nut M8

The rear blinkers remain in their original position.

Tip:

Fit all parts and screw on not too strong.

After mounting all parts, the screws should be tightened to the torque specified.

This guarantees, that the kit is mounted without tension.



**Control all screw connections after the assembling for tightness!**  
Please notice our enclosed service information.



**Hepco & Becker GmbH**

**An der Steinmauer 6**

**D-66955 Pirmasens**

**Tel.: +49 6331 - 1453 - 100**

**Fax: +49 6331 - 1453 - 120**

**eMail: [vertrieb@hepco-becker.de](mailto:vertrieb@hepco-becker.de)**

**[www.hepco-becker.de](http://www.hepco-becker.de)**

# C-Bow Soft bag holder

APRILIA Shiver 750

up to date of manufacture 2009

APRILIA Shiver 750 GT

Item-no.:

630752 black



## Assembling instructions

Fastening of the adapter bow bottom:

Under the exhaust muffler.  
Use allen screws M6 x 30 with washers  
ø6,4.  
Original screws are obsolete.

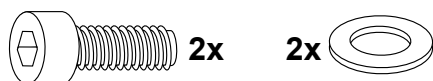

**1**

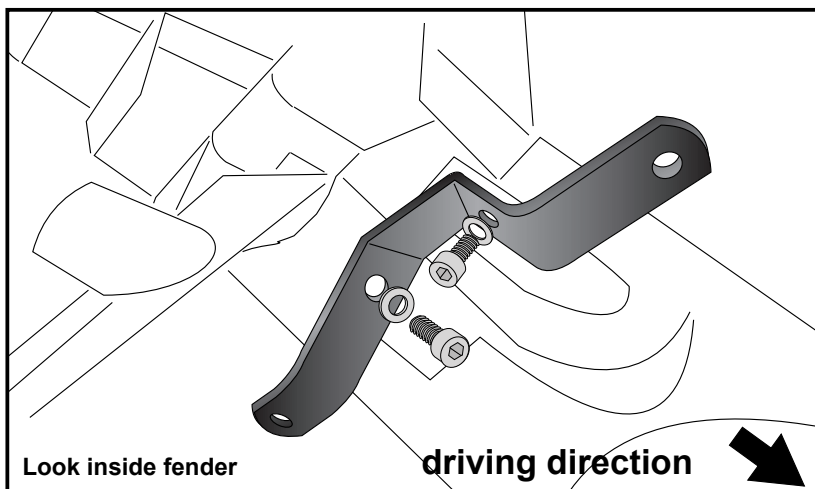

Fastening of the front adapters  
left and right:

at the free threaded holes behind the  
footrest brackets.  
Use countersunk head allen screws  
M6 x 20.

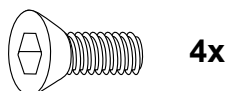

**2**

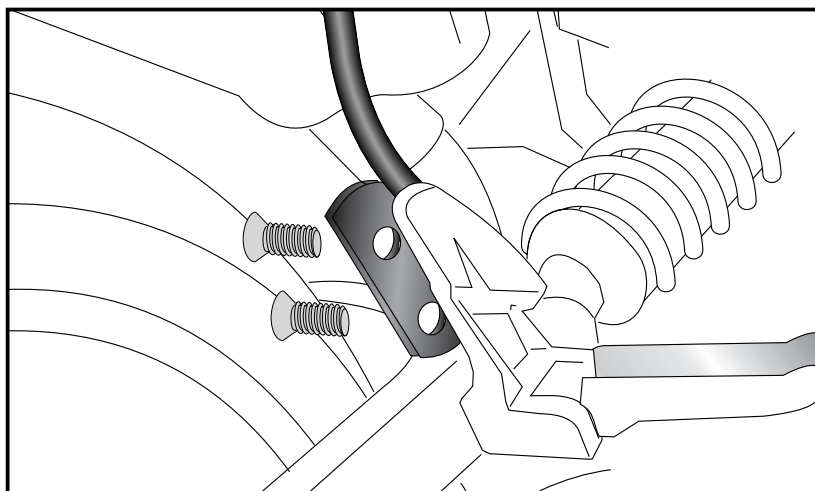

Fastening of the rear adapters  
left and right:

at the mounted adapter bow bottom (step  
1) with allen screws M8 x 25 and  
tensilock-nuts M8.

When mounting the c-bow together with  
an alurack, use allen screws M8 x 30.



**3**

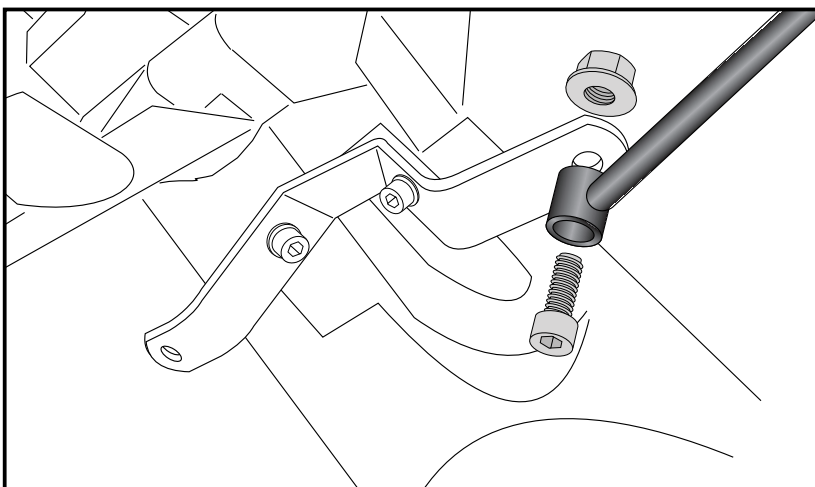

# C-Bow Soft bag holder

APRILIA Shiver 750

up to date of manufacture 2009

APRILIA Shiver 750 GT

Item-no.:

**630752** black



## Assembling instructions

Fastening of the C-Bow:

with hexagon bolts M6 x 16 and  
washers  $\varnothing 6,4$ .

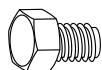

8x

8x

