

Gepäckbrückenverbreiterung

YAMAHA XT 1200 Z Super Tenere
bis Baujahr 2013

YAMAHA XT 1200 Z Super Ténéré
YAMAHA XT 1200 ZE Super Ténéré
ab Baujahr 2014

Artikel-Nr.:
8004531



Montageanleitung

Der Bausatz umfasst die folgenden Teile:

Stück	Bestellnr.	Bezeichnung
1	700007804	Gepäckbrückenverbreiterung
2	151.358	Senkinbusschrauben M8x130
2	151.302	Senkinbusschrauben M8x25
4	151.302	Senkscheiben ø8,4 x ø25mm

Stück	Bestellnr.	Bezeichnung
2	151.219	Aludistanzen Ø20xØ9x13mm
2	151.220	Kunstoffscheibe Ø24xØ8,4x2mm
2	150.803	Tensilock-Mutter M8



Anzugsmomente des Motorradherstellers beachten!
Nach der Montage alle Verschraubungen auf festen Sitz kontrollieren!
Bitte beachten Sie unsere beigefügten Serviceinformationen.

Als weiteres Zubehör lieferbar:

Seitenträger Lock it (abnehmbar), Motorschutzbügel, Tankschutzbügel, Lampengitter, Motorschutzplatte, Griffschutz, Kardanschutzz...und viel weiteres Zubehör



Hepto & Becker GmbH
An der Steinmauer 6
66955 Pirmasens

Tel.: 06331 - 1453 - 100
Fax: 06331 - 1453 - 120
eMail: vertrieb@hepto-becker.de
www.hepto-becker.de

Gepäckbrückenverbreiterung

YAMAHA XT 1200 Z Super Tenere
bis Baujahr 2013

YAMAHA XT 1200 Z Super Ténéré
YAMAHA XT 1200 ZE Super Ténéré
ab Baujahr 2014



Artikel-Nr.:
8004531

Montage

Vorbereitung vorne: ①
Die Original Schrauben lösen (entfallen)
Aludistanzen $\text{Ø}20 \times \text{Ø}9 \times 13$ mm über der
Bohrung positionieren.

Vorbereitung hinten: ②
Kunststoffscheiben $\text{Ø}24 \times \text{Ø}8,4 \times 2$ mm über
der Bohrung positionieren.

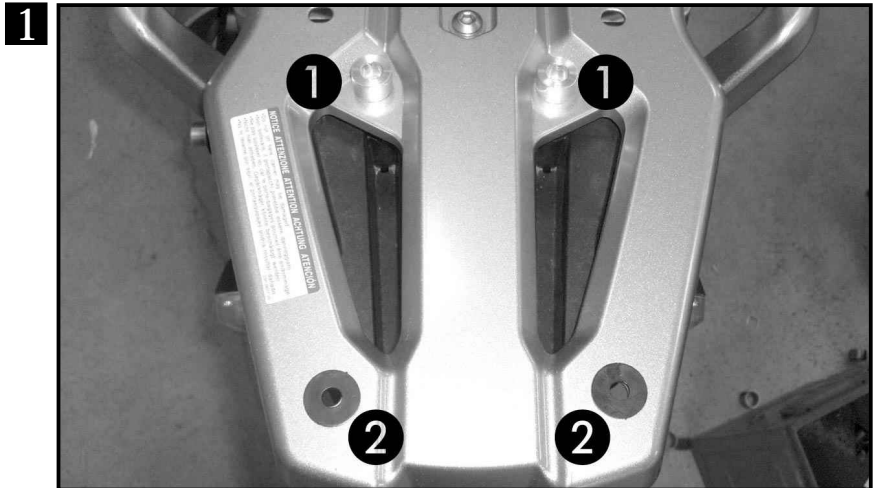

Befestigung der Verbreiterung vorne: ③
Zur Verschraubung die Senkinbus-
schrauben M8x 130 sowie Senkscheiben
 $\text{Ø}8,4$ verwenden.

Befestigung der Verbreiterung hinten: ④
An den freien Bohrungen der Original
Brücke mit den Senkinbusschrauben
M8x25 sowie Senkscheiben $\text{Ø}8,4$.
Von unten mit den Tensilock-Muttern M8
verschrauben.

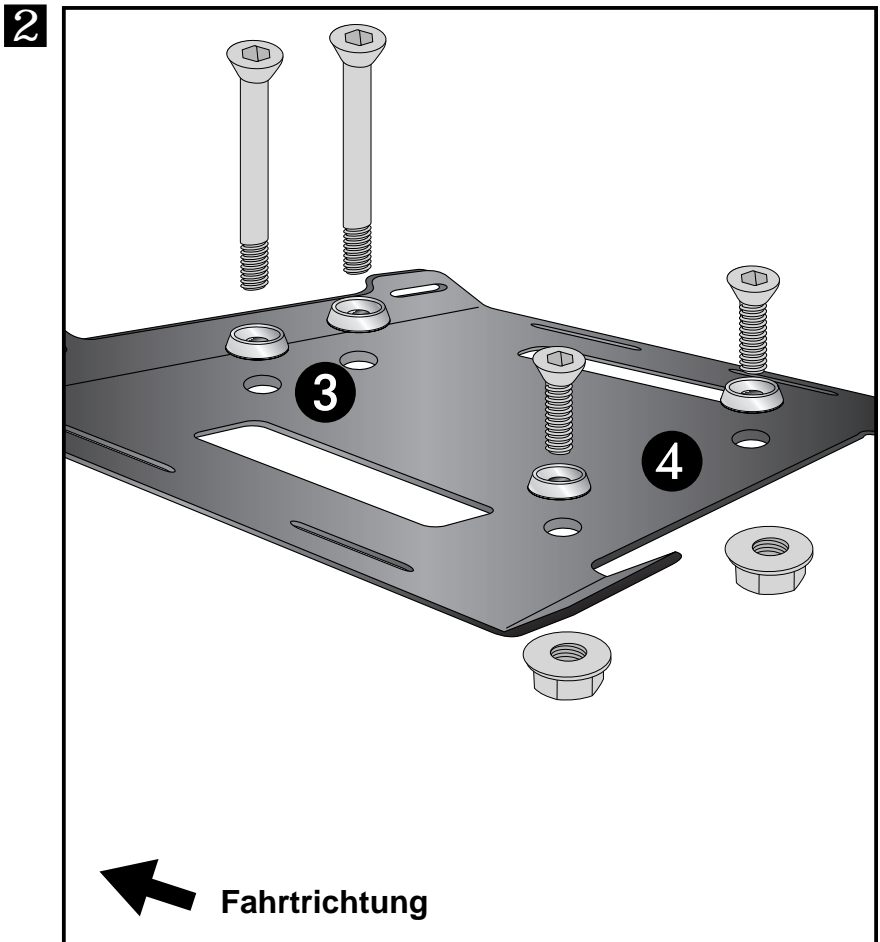
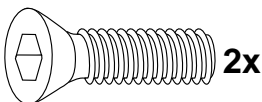
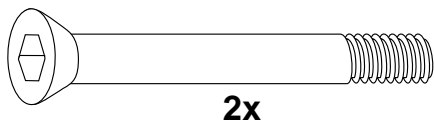

Enlargement for rear carrier

YAMAHA XT 1200 Z Super Tenere
up to date of manufacture 2013

YAMAHA XT1200 Z Super Ténéré
YAMAHA XT1200 ZE Super Ténéré
from date of manufacture 2014



Item-no.:
8004531

Assembling instructions

The kit includes the following parts:

Quant	item no.	description	Quant	item no.	description
1	700007804	enlargement	2	151.219	spacer Ø20xØ9x13mm
2	151.358	countersunk head allen screw M8x130	2	151.220	plastic washer Ø24xØ8,4x2mm
2	151.302	countersunk head allen screw M8x25	2	150.803	tensilock nut M8
4	151.302	countersunk washer ø8,4 x ø25mm			



Control all screw connections after the assembling for tightness!
Please notice our enclosed service information.

Also available:

Side carrier Lock it (removable), Engine guard, Tank guard, Skid plate, Headlight grilles
and much more accessories.



Hepco & Becker GmbH
An der Steinmauer 6
D-66955 Pirmasens
Germany

Tel.: +49 6331 - 1453 - 100
Fax: +49 6331 - 1453 - 120
eMail: vertrieb@hepco-becker.de
www.hepco-becker.de

Enlargement for rear carrier

YAMAHA XT 1200 Z Super Tenere
up to date of manufacture 2013

YAMAHA XT1200 Z Super Ténéré
YAMAHA XT1200 ZE Super Ténéré
from date of manufacture 2014



Item-no.:
8004531

Assembling instructions

Preparing front: ①

Unscrew original screw - they are obsolete.

Put spacers $\text{Ø}20 \times \text{Ø}9 \times 13$ mm over the borings.

Preparing rear: ②

put plastic washers $\text{Ø}24 \times \text{Ø}8,4 \times 2$ mm over the borings.

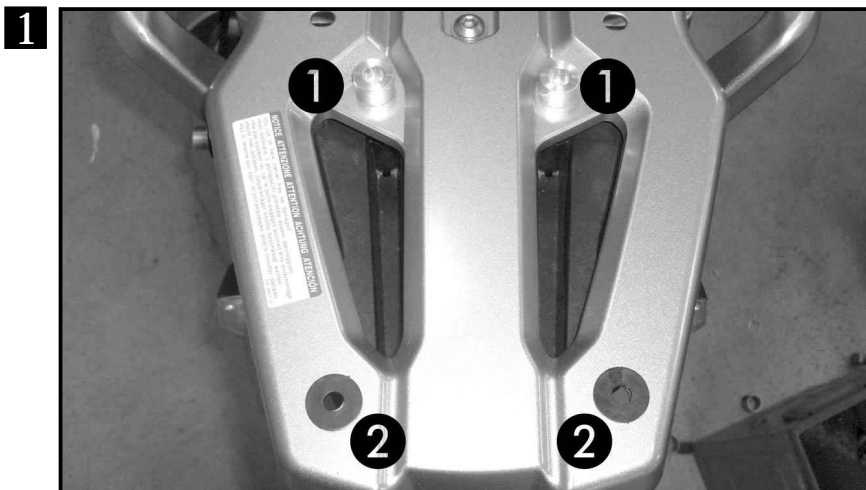

Fastening of the enlargement front: ③

with countersunk head allen screw M8x130 and countersunk washers $\text{Ø}8,4$.

Fastening of the enlargement rear: ④

with countersunk head allen screw M8x25 and countersunk washers $\text{Ø}8,4$.

Fix with tensilock nuts M8.

